



PNEUMO-MECHANICAL SHAFT 580 P/M

TIDLAND SERIES 580 P/M PNEUMO-MECHANICAL SHAFT

The Tidland series 580P/M shaft combines the advantages of mechanical and pneumatic shafts.

The expanding elements are permanently locked by springs during normal operation but may be quickly collapsed by compressed air, allowing faster reel handling.

BENEFITS

Three concentric rows of expanding lugs with high gripping force guarantee accurate centering. The advantages of this mechanical locking system are:

- outstanding concentricity and 'truth-of-run' characteristics
- the avoidance of roll flexing
- increased winding accuracy

APPLICATION

These features allow the shaft to be used in a wide variety of unwind and rewind applications including sensitive materials in the film and paper industries.

The mechanical locking of the 580P/M is inherently more reliable than pneumatic locking which greatly improves the working



reliability of the shaft. This is of particular benefit to applications with long continuous production runs as in the case of the cast film industry.

FEATURES

The 580P/M is designed to suit applications where high loads are run at high speeds. On core sizes of 76mm internal diameter the shaft has an operating speed range of 150 – 700metres per minute. It can be used with 1500mm wide rolls up to 1270mm in diameter at weights of up to 2000kg.

The high torque capacity of the shaft makes quick accelerations and rapid emergency stops possible.

In addition shaft handling is enormously simplified compared to

conventional mechanical shafts. Supplying compressed air collapses the expansion lugs in an instant, reducing reel change over times and improving overall productivity.

AVAILABILITY

Each shaft is custom made to suit your particular application. However the modular design allows fast and economical production of both the shafts and their spare parts.

Behind the 580P/M stands the Tidland company with an industry wide reputation for producing high quality reliable products coupled with the backup of a worldwide after sales service and support network.

WINDING SHAFT 580 P/M

STRUCTURE

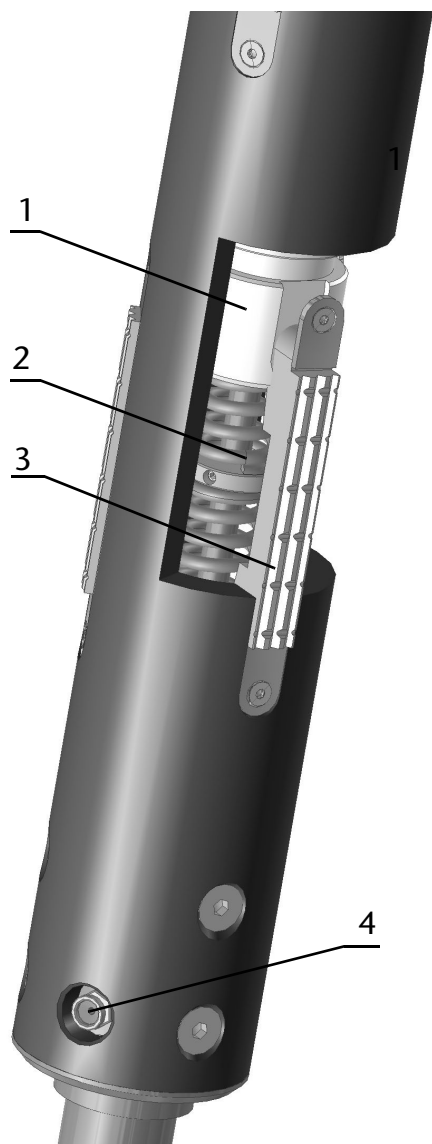

- 1 - Wedge block
- 2 - Compression spring
- 3 - Lug
- 4 - Air release valve

SPECIFICATIONS

Model	Core I.D. (mm)	Body length (mm)	Torque capacity (Nm)	Shaft weight without journals (kg)
Type LA	70	500	470	6
Type LA	70	1000	940	12,3
Type LA	70	1500	1648	16
Type LA	70	2000	2119	22
Type LA	70	2500	2826	25,7
Type LS	70	500	470	10
Type LS	70	1000	940	20,3
Type LS	70	1500	1648	27,8
Type LS	70	2000	2119	40
Type LS	70	2500	2826	45,3
Type LA	76	500	526	7
Type HA	76	500	526	7,6
Type LA	76	1000	1040	13,6
Type HA	76	1000	1040	14,7
Type LA	76	1500	1818	17,3
Type HA	76	1500	1818	18,9
Type LA	76	2000	2338	24
Type HA	76	2000	2338	26,1
Type LA	76	2500	3117	27,7
Type HA	76	2500	3117	30,3
Type LS	76	500	526	11,5
Type HS	76	500	526	13
Type LS	76	1000	1040	22,6
Type HS	76	1000	1040	25,6
Type LS	76	1500	1818	30,6
Type HS	76	1500	1818	35
Type LS	76	2000	2338	41,8
Type HS	76	2000	2338	47,7
Type LS	76	2500	3117	49,7
Type HS	76	2500	3117	57

Fife-Tidland GmbH
 Fifestraße 1
 65779 Kelkheim, Deutschland
 Siemensstraße 13-15
 48683 Ahaus, Deutschland
 Phone: +49-6195-7002-0
 Fax: +49-6195-7002-933
 E-Mail: info@maxcess.de
<http://www.maxcess.de>

Fife-Tidland (UK) Ltd.
 70-72 Manchester Road
 Denton/Manchester M34 3PR
 Great Britain
 Phone: +44-161-320-2000
 Fax: +44-161-320-4513
 E-Mail: sales_uk@maxcess.de
<http://www.maxcess.de>

Tidland Corporation
 Post Office Box 1008
 Camas, WA 98607, USA
 Phone: +1-360-834-2345
 Toll-Free: +1-800-426-1000
 Fax: +1-360-834-5865
 E-Mail:
tidlandmarketing@tidland.com
<http://www.maxcessintl.com>

COMPANIES OF **MAXCESS**
INTERNATIONAL

